

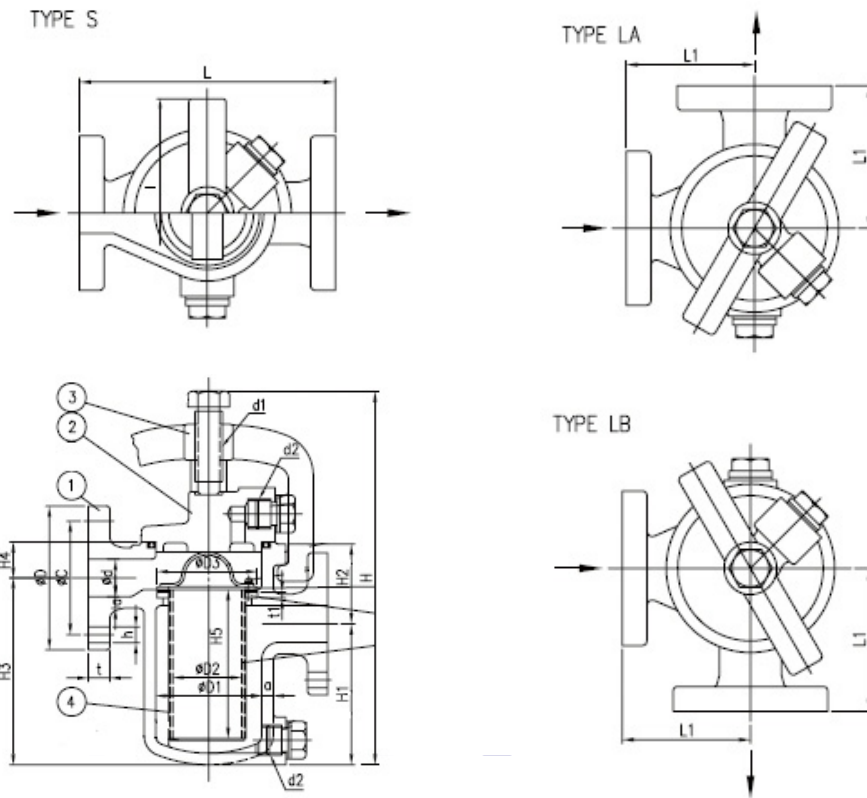

MARINE CAST IRON SIMPLEX OIL STRAINER - JIS F7209 (1)

(dia. 25A to 40A)



No.	Component	Material
1	Body	FC200
2	Cover	FC200
3	Yoke	SS41 or FCD45
4	Filter cylinder	SS41

Nominal dia.	Test Pressure Mpa[kgf/cm ²]
25A to 300A	0.74 [7.5]

Type of fluid	Fluid temperature	MAX working Pressure Mpa[kgf/cm ²]
Fuel oil	60°C or less	0.49 [5]
Lubricating oil	80°C or less	

Size	d	L	L1	Flange					H	Body				Filter cylinder			kg
				D	C	No.	h	t		H1	H2	H3	H4	D2	D3	H5	
25A	25	190	95	95	75	4	12	14	240	91	55	123	23	48	67	100	6.58
32A	40	260	130	115	90	4	15	16	315	145	75	188	32	86	107	155	14.8
40A	40	260	130	120	95	4	15	16	315	145	75	188	32	86	107	155	15.0